

Art. - Nr.: 3510



1

8 - 99

15 min. - ∞

Jigsawman



Jigsawman der Formwandler! Ziel dieses Puzzles ist es, aus den mit einem Seil verbundenen Teilen des Jigsawmans einen Würfel zu bauen. Anschließend wandeln Sie ihn zurück in den Jigsawman, um ihn in verschiedenen Baufiguren und eigenen Kreationen aufleben zu lassen.

Jigsawman



Jigsawman the shape shifter! The aim of this puzzle is to build a cube out of the Jigsawman parts, which are connected with a cord. Afterwards, you can transform him back and give him a new lease of life in differently constructed figures of your own creations.

Jigsawman



Jigsawman le métamorphe ! Le but de ce jeu est de construire un cube avec les pièces du Jigsawman reliées par une cordelette. Pour finir, vous le retransformez en diverses figures de construction et donner vie à vos propres créations.

Jigsawman



¡Jigsawman el cambiaformas! El objetivo de este puzzle es construir un dado con las partes del Jigsawman atadas con una cuerda. A continuación, se reconvierte para crear nuevas figuras y dar vida a creaciones propias.

Lösung / Solution / Solution / Solución

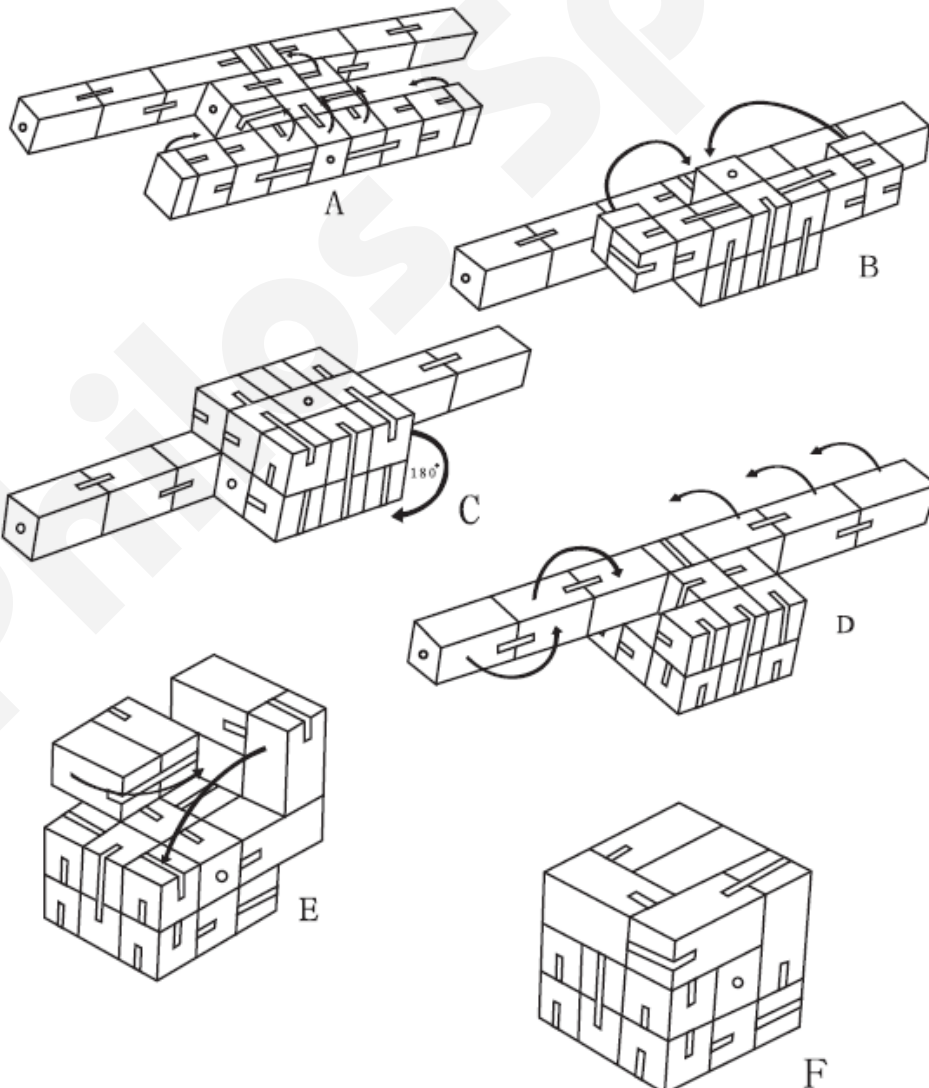

Philos GmbH & Co. KG
Friedrich-List-Str. 65
33100 Paderborn
www.philosspiele.de

verschiedene Figuren / different Solutions / diverses Figures / diferentes Figuras

